

दक; क्य; । गक; द हकडे । ज {क.क वफ/ककjh
कगM+d"; dj.k ; कst uk] jhok/e-i z½

1.A

। ज पुकRed <kpk (Organizational Set up)

**OFFICE OF THE ASSISTANT SOIL CONSERVATION OFFICER
(R.R.S.) REWA(M.P.)**

01	ofj"B dF"K fodkl vf/kdkjh	05 in
02	ekufp=dkj	01 in
03	y[kki ky	01 in
04	। गक; द xM&nks	01 in
05	। गक; द xM&rhU	01 in
06	vuj[kd	01 in
07	। o[j	15 in
08	p[re[05 in
09	HkR;	02 in
10	pk[dhkj	1 in
11	fu; fer ufef[kd okgu pkyd	1 in
		; kx 35 in

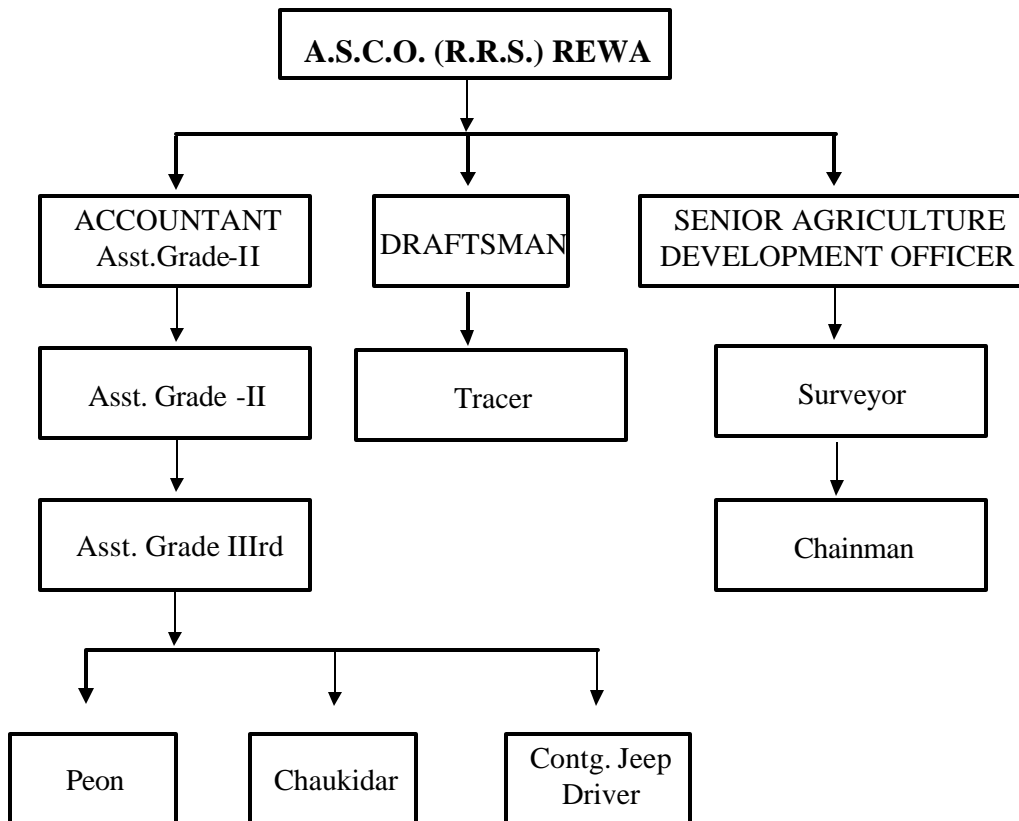

1.B. Functions and duties of each unit of the Office (1 to 2 page)

S.No.	Unit/Section	Designation	Functions performed
01	Administrative Section Jh , u-, y-xlrk	I gk; d Hkfe I j {k.k vf/kdkjh	i z kkl fud , oar duhdh mi I Hkx dk I á wZ fu; æ.k
02	y[kk Jh , I -dfeJ	y[kki ky	y[kk d{k dk I á wZ dk; Z
03	LVkj @LFkki uk Jh ch-i-h-fl g	I gk; d xM&nks	LVkj , oa LFkki uk dk I á wZ dk; Z
04	fjdkMZ : e Jh ch-i-h- fl g	I gk; d xM&nks	fjdkMZ dk I á wZ i Hkj
05	vkod@tkod Vkbi Jh vfu:) fl g	Vj j	vkod&tkod Vkbi dk; j Mkd vkfn dk I á wZ dk; Z
06	rduhdh Jh vkj-i-h-f) onh	ekufp=dkj	rduhdh dk; Z

2- Work distribution order of each officer can be updated and put in the following format. U/S 4.1 (b)(ii)

S.No.	Name	Designation	Remuneration	Duties
01	Jh , u-, y-xlrk	I gk; d Hkfe I j {k.k vf/kdkjh	o\$rud	i l kkl fud , oarduhdh
02	Jh , l -dsfeJ	I gk; d xM&nks ½ys[kki ky½	o\$rud	ys[kk 'kk[kk dk dk; Z
03	Jh chi hfl g	I gkxM&nks	o\$rud	LFkki uk@LVkj@dSk
04	Jh vfu:) fl g	vuj\$[kd	o\$rud	vkod@tkod] Vki
05	Jh eksrhyky xlrk	I gkxM&rhv	o\$rud	vkpfyd i z[kd] dk; kZ ea vkod tkod 'kk[kk dk dk; Z ¼ yXu½
06	Jh vo/kjkt fl g	I o\$ j	o\$rud	jk"Vh; tyxg.k {ks= , oa Hkfe I j {k.k dk; } fo-[k.M xaxD
07	Jh , e-i h-feJk	I o\$ j	o\$rud	jk"Vh; tyxg.k {ks= , oa Hkfe I j {k.k dk; } fo-[k.M xaxD
08	Jh ch, y-'kpyk	I o\$ j	o\$rud	jk"Vh; tyxg.k {ks= , oa Hkfe I j {k.k dk; } fo-[k.M xaxD
09	Jh x.k\$ k fl g	I o\$ j	o\$rud	jk"Vh; tyxg.k {ks= , oa Hkfe I j {k.k dk; } fo-[k.M fl jek\$
10	Jh eksgu fl g	I o\$ j	o\$rud	jk"Vh; tyxg.k {ks= , oa Hkfe I j {k.k dk; } fo-[k.M fl jek\$
11	Jh Ogh-i h-Jhokl	I o\$ j	o\$rud	jk"Vh; tyxg.k {ks= , oa Hkfe I j {k.k dk; } fo-[k.M tok
12	Jh t\$Mhfl g	I o\$ j	o\$rud	jk"Vh; tyxg.k {ks= , oa Hkfe I j {k.k dk; } fo-[k.M tok

13	Jh jktHkku 'kekZ	HkR;	oʃfud	dkʃky; hu dk; Z
14	Jh d: .kk iʃ kn f) onh	HkR;	oʃfud	dk; kʃy; HkR;
15	Jh xtʃnz cgknj fl ʃ	pʃueʃ	oʃfud	jk-t-xz{kʃ= ul jh Mhkkʃk
16	Jh euhʃk dʃkj nʃs	pʃueʃ	oʃfud	jk-t-xz{kʃ= ul jh ekMkʃ
17	Jh jkey[ku oekZ	pʃueʃ	oʃfud	jk-t-xz{kʃ= ul jh [kʃk
18	Jh iʃorh oekZ	pʃueʃ	oʃfud	dk; kʃy; hu HkR; dk; Z
19	Jherh l kʃu; k dkNh	pʃueʃ	oʃfud	dk; kʃy; hu dk; Z
20	Jh jktef.k 'kʃyk	pkʃhknj	oʃfud	jkf=dkyhu M; Wʃ

**3- Decision Making Process in Graphic Form (One Page) U/S
4.1 (b) (iii)**

OFFICE OF SUB DIVISIONAL AGRI. OFFICER. REWA(M.P.)

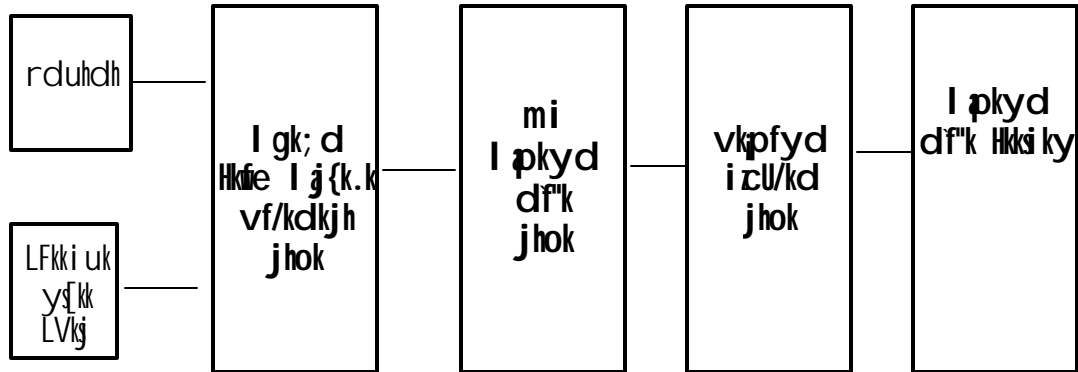

4- A) Time, norm, if decided by the organisation. U/S 4.1(b)(iv)

B) Quality Norms, if decided by the organisation.

C) Quantity target, for the office work to be done in the year.

01	QDI @rkj	ml h fnu
02	'kkl u l s i klr i =ka dh tkudkjh	3 fnol
03	v) lkk- i = tks 'kkl u l pk- df"k , oa vl;	3 fnol
04	vl; i =ka dh tkudkjh	7 fnol

5- List of Acts, Rules, Regulations Manuals, Circulars related with the functioning of office constitution the organization. (Original text to be given in electronic form) U/S 4.1 (b)(v)

Acts

NIL

Rules

- 01- e/; i n s k o r u f u / k k j . k f u ; e
- 02- e-i z e y / H k r f u ; e
- 03- i q j h f { k r v o d k ' k f u ; e
- 04- e-i z ; k = k H k j k f u ; e
- 05- e-i z f p f d R l k i f j p ; k z f u ; e
- 06- e-i z H k k / k j Ø ; f u ; e
- 07- i q j h f { k r o r u f u / k k j . k f u ; e 1998
- 08- e g x k b z H k R r k v a r f j e j k g r f u ; e
- 09- l k e l u ; H k f o " ; f u f / k f u ; e
- 10- e-i z i k k u f u ; e 1976
- 11- x k s i u h ; i f r o n u f u ; e , o a i f Ø ; k

Regulations

' k k l u d h u h r f u / k k j . k d s v k / k k j i j m D r f u ; e k a d k i k y u d j u k A

Manuals

- 01- H k f e l j { k . k e s u p y A

Circulars

e/; i n s k l k e l u ; i q r d i f j i = A

**06- Statement of various categories of documents held by it
or under its control U/S 4.1 (b) (vi)**

S. N.	Name of Documents	Kind of Document like Microfilm, Register, Books, Diskette etc.	Nature and content of Document	Duration of Records
(1)	(2)	(3)	(4)	(5)
LFkki uk 'kk[kk				
01	Lohdr@Hkjs in dh tkudkjh	uLrh	Lohdr@Hkjs inka I Ecl/kh vfhkys[k , oa i=kpkj uLrh	yeh vof/k rd
02	I ok fuoRr	uLrh	depkfj ; ka dh I okfuorR I Ecl/kh LFkkbz uLrh	yeh vof/k rd
03	depkfj ; ka dh I ok i qLrdka i qLrdk; a	I ok i qLrdka	depkfj ; ka ds I ok vfhkys[k I Ecl/k foofj.k	depkfj ; ka dh I ok mi fLFkr I s I ok fuoRr fnukad rd
04	depkfj ; ka dh 0; fDrxr-uLrh	uLrh	I ok I s I Ecl/kh vfhkys[kka dk I dkj .k] i = , oa vkn's kka dk I ag	depkfj ; ka dh I ok mi fLFkr I s I ok fuoRr fnukad rd
05	mi fLFkr i ath	i ath	depkfj ; ka dh ekfl d mi fLFkr dk foofj.k	ekfl d
06	uLrh jftLVj	i ath	[kys tkus okyh ubz uflr; ka dk foofj.k	okf'kd
07	oru of) i ath	i ath	depkfj ; ka dk oru of) Lohdr i ath	I okfuorR fnukad rd
08	Øektur uLrh	uLrh	depkfj ; ka dh foHkxh; Øektur I Ecl/kh tkudkjh	I okfuorR fnukad rd
09	I ok fuoRr I cak	uLrh	I ok fuoRr I cak tkudkjh	I okfuorR fnukad rd
10	ofj"Brk I dkj .k ckor-	uLrh	ofj"Brk fu/kkj .k I cak tkudkjh	I okfuorR fnukad rd
ys[kk 'kk[kk				
11	dSk cp	i ath	0; ; foofj.k	yeh vof/k rd yxkrkj
12	fcy jftLVj	i ath	ns d Hkqrku foofj.k	yeh vof/k rd yxkrkj
13	dUhtV	i ath	fcy dk foofj.k	yeh vof/k rd yxkrkj

S. N.	Name of Documents	Kind of Document like Microfilm, Register, Books, Diskette etc.	Nature and content of Document	Duration of Records
(1)	(2)	(3)	(4)	(5)
14	, D; j; jly	i ath	Hkqrku I ECU/kh	yach vof/k rd yxkrkj
15	pdl jftLVj	i ath	pdl foof.k i ath	yach vof/k rd yxkrkj
16	fcy VktV cpd	i ath	dkkky; eans d i Lrq djus grq i ath	yach vof/k rd yxkrkj
17	cd MKV jftLVj	i ath	cd MKV dh tkudkjh MKV vkod&tkod½	yach vof/k rd yxkrkj
18	vfxe i ath	i ath	vfxe i ath dVks-h i wkz gkus rd	yach vof/k rd yxkrkj
19	vfxe dVks-h i ath	i ath	1-vukt] 2-R; ksj] 3 I kell; Hkfo"; fuf/k dVks-h i ath vkfn	yach vof/k rd yxkrkj
20	I k-Hk-fu-@Mh-i-h-, Q- i ath	i ath	depkfj; ka dk I k-Hk-fu-@Mh-i-h- , Q- yqkk foof.k i ath	yach vof/k rd yxkrkj
21	I k-Hk-fu- i kl cpd	i ath	I Hkh depkj@vf/kdkjh] vyx&vyx I akkfjr dh tkrh gA	yach vof/k rd yxkrkj
22	foHkxh; Hkfo"; fuf/k ystj	i ath	prFkZ Js kh depkfj; ka dk yqkk foof.k i ath	yach vof/k rd yxkrkj
23	fpfdRI k i ath	i ath	depkfj; ka ds fpfdRI k ns d Hkqrku I ECU/kh	yach vof/k rd yxkrkj
24	; k=k ns d i ath	i ath	depkfj; ka ds ; k=k ns d Hkqrku I ECU/kh	yach vof/k rd yxkrkj
25	Ogkmpj uLrh	uLrh	Hkqrku 'kqk Ogkmpj uLrh	i kjkk I syxkrkj
Hk. Mkj 'kk[kk				
26	Hk. Mkj dk Hkksrd I R; ki u uLrh	uLrh	vLFkkbz Hk. Mkj ds Hkksrd I R; ki u I ECU/kh	i kjkk I syxkrkj
27	Ø; I ECU/kh uLrh	uLrh	I kexh Ø; dk; bkgh uLrh	i kjkk I syxkrkj
28	vi yqku i Lrko uLrh	uLrh	VW&QW's I kexh dh u"V grq dk; bkgh	i kjkk I syxkrkj
29	Hk. Mkj I kexh i ath	i ath	LFkkbz Hk. Mkj I kexh dk bntt	i kjkk I syxkrkj
30	LVS kujh i ath	i ath	dk; ky; mi ; ksx grq LVS kujh	i kjkk I syxkrkj
31	onhZ Ø; i ath	i ath	prFkZ Js kh depkfj; ka dks onhZ i nk; I ECU/kh	i kjkk I syxkrkj

S. N.	Name of Documents	Kind of Document like Microfilm, Register, Books, Diskette etc.	Nature and content of Document	Duration of Records
(1)	(2)	(3)	(4)	(5)
32	fctyh ns d iath	iath	dk; kly; dk fctyh ns d Hkqrku	i kjkk l syxkrkj
33	dUT; wfcy iath	iath	l keku; mi; kx dh l kexh 1/2; l kexh 1/2	i kjkk l syxkrkj
34	fel yfu; l iath	iath	l keku; gsm fj l hiv bñkt iath	i kjkk l syxkrkj
35	,e-ih-Vh-l h-&6 iath	iath	j l hn cpl jftLVj	i kjkk l syxkrkj
36	eLVj jky iath	iath	eLVj jky bñkt iath	i kjkk l syxkrkj
37	Hkou fdjk; k iath	iath	Hkou fdjk; k ns d bñkt iath	i kjkk l syxkrkj
rduhdh 'kk[kk				
38	odl pktl iath	iath	; kstuk l EclU/kh ns dka ds tkp mijkr bñkt	i kjkk l syxkrkj
39	rduhdh Lohdfr iath	iath	vf/kdkj {ks= ds vUrxr~ rduhdh Lohdfr dk; l	i kjkk l syxkrkj
40	il kkl dh; Lohdfr iath	iath	vf/kdkj {ks= ds vUrxr~ rduhdh Lohdfr dk; l	i kjkk l syxkrkj
41	; kstuk iath	iath	ofj "Bky; Lohdfr i 'pkr~ ; kstukvka dk bñkt	i kjkk l syxkrkj

7- I- Structure of consultative committees in which public representatives are members including

Name of the Committee
Copy of the Orders/Circulars for formation
Functions
Members
Duties and responsibilities
Accessibility of minutes for public U/s 4.1 (b) (vii)

II Proceedings, Minutes of the Meetings (copy to be made available and be given in the electronic form with hypertext link)

NIL

08-

I Name of the Board, Council, Committees etc. including members and their qualifications. (Original text to be given in electronic form) U/S 4.1 (b) (viii)

S.No.	Name of the Body	Name of the members	Qualifications
NIL			

II Order of the formation

(original text to be given in electronic form and to be hyper linked)

III Charter/Memorandum of Articles of Association.

(Original text to be given in electronic form and to be hyper linked)

(IV) Govt. instruction for the way in which meeting will be conducted (Original text to be given in electronic form and be hyper linked)

V Whether open to public or not

VI Availability of the proceedings /minutes of the last meetings (Original text to be given chronologically in electronic form and to be hyper linked)

NIL

9. Directory of the officers and employees (to be linked with treasury data bank) U/S 4.1 (b) (ix)

S.N.	Name	Designation	Address & Contact No., if any
01	Jh , u-, y-xtrk	I gk; d Hkfe I j{k.k vf/kdkjh	dhfrØkflur ds i kl] fui fu; k] jhok
02	Jh , l -dsfeJ	I gk; d xM&nks ½ys[kki ky½	, y-vkbzth- 3@27@310] ug: uxj jhok
03	Jh ch-i-h-fl g	I gk-xM&nks	, y-vkbzth- 3@27@310 ug: uxj] jhok
04	Jh vfu:) fl g	vuj\$[kd	, e-vkbzth- 5] i) e/kj dkyksh jhok
05	Jh ekryky xtrk	I gk-xM&riu	, e-vkbzth- 14] i) e/kj dkyksh jhok
06	Jh vo/kjkt fl g	I oš j	fo-[k.M -xaxo] jhok
07	Jh , e-i-h-feJk	I oš j	fo-[k.M -xaxo] jhok
08	Jh ch, y-'kpyk	I oš j	fo-[k.M -xaxo] jhok
09	Jh x.kk fl g	I oš j	fo-[k.M fl jek\$] jhok
10	Jh ekgu fl g	I oš j	fo-[k.M fl jek\$] jhok
11	Jh Ogh-i-h-Jhokl	I oš j	fo-[k.M tok] jhok
12	Jh tsMh-fl g	I oš j	fo-[k.M tok] jhok
13	Jh jktHku 'kekZ	HkR;	i Mj-k] jhok
14	Jh d: .kk i d knf) onh	HkR;	fl jek\$ pk\$kgk] jhok
15	Jh xtbnzcgknj fl g	pšeš	jk-t-xz{kš= MHk\$ k ul jh
16	Jh euh" k d\$kj n\$š	pšeš	jk-t-xz{kš= ekMkš ul jh
17	Jh jkey[ku oekZ	pšeš	jk-t-xz{kš= [k\$ k ul jh
18	Jh i eorh oekZ	pšeš	fpjgyk dkyksh jhok
19	Jherh l kfu; k dkNh	pšeš	d\$fy; k] jhok
20	Jh jktef.k 'kpyk	pkšhmkj	<d\$gk] jhok

10- Monthly remuneration and compensation (to be linked with treasury Data Bank) U/S 4.1 (b) (x)

01- Office Staff

S.N	Name	Remuneration Gross Amount	Compensation
01	Jh , u-, y-xlrk	13595.00	&
02	Jh , l -dsfeJ	8109.00	&
03	Jh ch-i-h-fl g	8477.00	&
04	Jh ekshyky xlrk	7161.00	&
05	Jh vfu:) fl g	6790.00	&
06	Jh vo/kjkt fl g	9647.00	&
07	Jh e/kq mu i d kn feJk	9844.00	&
08	Jh ch-, y-'kpyk	9293.00	&
09	Jh x.ksk fl g	9450.00	&
10	Jh ekgu fl g	9293.00	&
11	Jh Qgh-i-h-Jhokl	9450.00	&
12	Jh tsMh-fl g	9450.00	&
13	Jh jktHkku 'kekZ	5142.00	
14	Jh d: .kk i d kn f) onh	5047.00	
15	Jh xtWnz cgknj fl g	5905.00	
16	Jh euh" k dckj nps	4976.00	
17	Jh jkey[ku oekZ	5126.00	
18	Jh iæorh oekZ	4804.00	
19	Jherh l kfu; k dkNh	4133.00	
20	Jh jktef.k 'kpyk	5516.00	

11 - Annual Budget allocation and Expenditure statement (to be linked with treasury Data Bank (U/S 4.1(b) (xi)

S. No.	Budget Head	Name of work	Year	Allocation	Expenditure
01	Plan 13-2402-00-102-0101-3142	oru HkÜks , oa dfUVutØI h	2005-06	590000.00	938192.00
02	80-4402-00-800 0101 - 3478-42-007	ekbØkekbu ½I pkbz ; kst uk½	2005-06	500000.00	–
03	13-2401-00-800-0701 - 1580-32-000	Hk&ty I Ø/kÜ ; kst uk	2005-06	45000.00	–

12- Programmes and beneficiaries U/S 4.1 (b) (xii)

A List of the Programmes (in electronic form)

B Norms for selection of the beneficiary (original text of the circular to be given in electronic form)

C Detailed Information

S No.	Name of the Programme	Administrative Department	Year	Amt. Allocated	No. of Beneficiaries
(1)	(2)	(3)	(4)	(5)	(6)
01	Hk&ty l d?kL	l pkyd df'k Hkkl ky	2005&06	45000-00	
02	ekbØkekuj	l pkyd df'k Hkkl ky	2005&06	500000-00	

**13- List of the recipients and nature of concession U/S 4.1(b)
(xiii)**

S.No.	Nature of concession	Name	Address	Year	Kind of support	Approximate value of Concession
			NIL			

**14- Information available in the office (Link with item 6) U/S 4.1
(b) (xiv)**

SN	Categories	Hard Copy	Electronic Form
1-	0; ; %yku½	¶ykih	
2-	rdudh tkudkjh	¶ykih	
3-	okgu l cakh	¶ykih	
4-	ctV	¶ykih	

15- Facility available (liabrary, Public counter etc.) to citizen for information U/S 4.1(b) (xv)

SN	Facility	Name of In charge	Duration of opening (time to be given)	Contract No. Telephone No.
		NIL		&

**16- Information about the PIO/Designation/Working experience
U/S 4.1(b) (xvi)**

Name : Jh ch-i h-fl g
 Designation : I gk; d xM&nks
 Tel. No. : &
 E-mail Address : &
 Place of Work and Address : dlk; kzy; I gk; d Hkrie I j {k.k vf/kdkjh %cgM% jhok
 Contract hours for public : 10%0 I qg I s 05%0 'kke rd

**17- Any other information in citizen related facilities U/S 4.1 (b)
(xvii)**

NIL