

i kpk; Z d'k foLrkj , oa i f'k{k.k d'lnz d'fuy; k] jhok 1/4-e-i 1/2

**ykd I pukf/kdkjh@I gk; d ykd I puk vf/kdkjh**

Øi	Lrj	ykd I puk vf/kdkjh	I gk; d ykd I puk vf/kdkjh	I puk I gk; d
1/4 1/2	1/2 1/2	1/3 1/2	1/4 1/2	1/5 1/2
01-	i kpk; I d'k foLrkj , oa i f'k{k.k d'lnz d'fuy; k jhok	Jh dsi h-i.k.Ms ] i kpk; I dk; k; mi I pkyd d'k jhok-e-i 1/2	Jh v'kkd d'k feJk] xk-d'fo-vf/k-] dk; k; i kpk; Z d'fo-, oa i f'k-d'lnz d'fuy; k jhok	Jh vfuy d'k feJk] xk-d'fo-vf/k-] dk; k; i kpk; Z d'fo-, oa i f'k-d'lnz d'fuy; k jhok

# I j pukRed <kpk (Organizational Set up)

i kpk; i  
 df"k foLrkj , oa i f'k{k.k dshz  
 dPfy; kj jhok/e -i z½

	in	
i kpk; Z	¼1½	
i f'k{k.k vf/kdkjh	¼1½	
OkeZ eLst eBV fo'kSkK	¼1½	
jSM; ks I Ei dZ vf/kdkjh	¼1½	
i f'k{k.k vf/kdkjh/efgyk½	¼1½	
S.A.D.O. df"k i n'kL ¼i q "k½	¼1½	
A.D.O. df"k i n'kL ¼efgyk½	¼1½	
xkeh.k df"k foLrkj vf/kdkjh	¼2½	
I gk; d xM&1 ¼ef; fyfi d ½	¼1½	dk; jr I gk; d xM&2
I gk; d xM&3	¼1½	
okgu pkyd	¼1½	
HR; @pkshnkj	¼2½	

## 1.B. Functions and duties of each unit of the Office ( 1 to 2 page)

S.No.	Unit /Section	Designation	Function performed
<b>01</b>	<b>i' kkl fud</b>		
	Jh dsi h-i k. Ms	i' kkl fud i' kkl fud; i' d'k foLrj , oa i' kkl fud d'bz d'bz; k jhok	I a wkl fu; a. k
<b>02</b>	<b>, dkmUV</b>		
	Jh jkecgkj frokjh	I gkxM&3	y[kk d{k@d's' k; j
<b>03</b>	<b>LFkki uk</b>		
	Jh d'bz oj fl g	I gkxM&2	LFkki uk@vklMV
<b>04</b>	<b>LVkj</b>		
	Jh d'bz oj fl g	I gkxM&2	MM LVkd] LV's kujh dUT; w'fscy I kexh
<b>05</b>	<b>rduhdh</b>		
	Jh v'kkd d'bz feJk	xk-d-fo-vf/kdkjh	i' kkl fud 'kk[kk
	Jh vfuy d'bz feJk	xk-d-fo-vf/kdkjh	Okel i' kkl fud
	Jherh I jkst fl g	efgyk d'bz in'kz	i' kkl fud

**2- Work distribution order of each officer can be updated and put in the following format. U/S 4.1 (b)(ii)**

S.No.	Name	Designation	Remuneration	Duties
01	Jh dsi h-i.k.Mş	i Hkkjh i kpk; Z	oşfud	I á wkZ fu; æ .k
02	Jh dşMhfl g	I gkxM&2	oşfud	LFkki uk@vkfMV@LVkj
03	Jh vkj-chfrokjh	I gkxM&3	oşfud	dş' k; j@yşkk dk I eLr i Hkkj
04	Jh v'kkd dşkj feJk	xk-d-fo-vf/k	oşfud	i f' k{k. k 'kk[kk dk I á wkZ i Hkkj
05	Jh vfuy dşkj feJk	xk-d-fo-vf/k	oşfud	QkeZ i Hkkjh vkod] tkod

### 3- Decision Making Process in Graphic Form (One Page) U/S 4.1 (b) (iii)

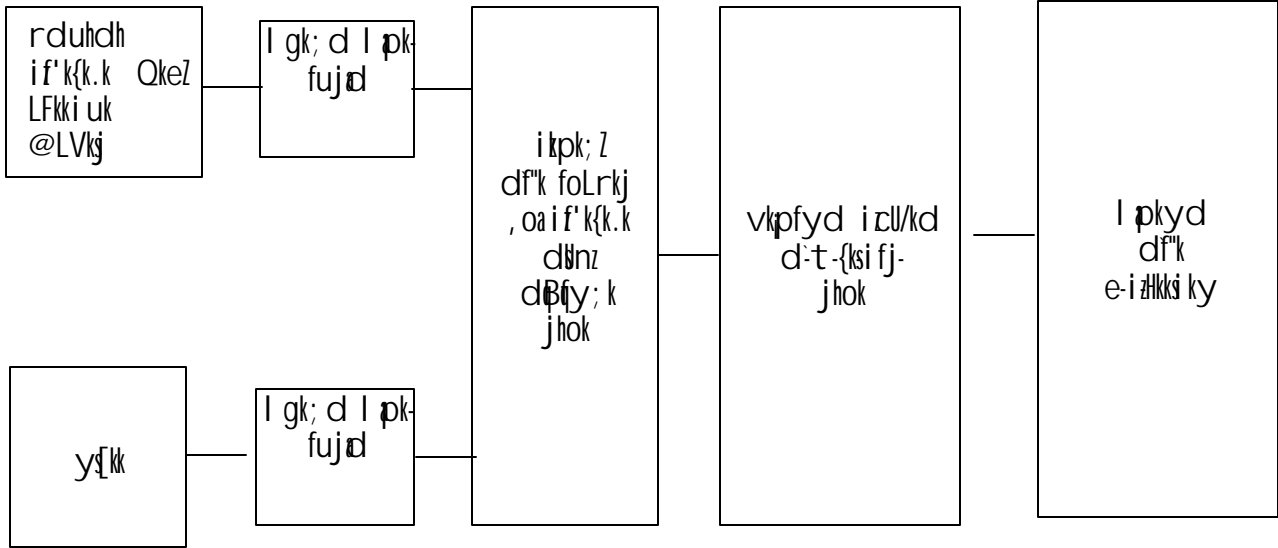

**4- A) Time, norm, if decided by the organisation. U/S 4.1(b)(iv)**

B) Quality Norms, if decided by the organisation.

C) Quantity target, for the office work to be done in the year.

01	QDI @rkj	ml h fnu
02	'kkl u l s i k l r i = k a d h t k u d k j h	3 f n o l
03	v) l k k - i = t k s ' k k l u l p k - d f ' k , o a v l ;	3 f n o l
04	v l ; i = k a d h t k u d k j h	7 f n o l

5- List of Acts, Rules, Regulations Manuals, Circulars related with the functioning of office constitution the organization. (Original text to be given in electronic form) U/S 4.1 (b)(v)

**Acts : NIL**

**Rules**

- 01- e/; in'sk oru fu/kkj .k fu; e
- 02- e-izewyHkr fu; e
- 03- i qj hf{kr vodk'k fu; e
- 04- e-iz; k=k HkÜkk fu; e
- 05- e-izl sk nšud dk; Bkkfjr vkdfLedrk depljh fu; e
- 06- e-izfpfdRI k ifjp; kz fu; e
- 07- e-izHk&kj Ø; fu; e
- 08- egxkbZ HkRrk varfje jkgr fu; e
- 09- I kekU; Hkfo"; fuf/k fu; e
- 10- e-izi dku fu; e 1976
- 11- e-izvkpj .k fu; e 1965

**Regulations**

'kkI u dh uhfr fu/kkj .k ds vk/kkj ij mDr fu; eka dk ikyu djukA

**Manuals : NIL**

**Circulars :**

e/; in'sk I kekU; i qrd ifji =

**06- Statement of various categories of documents held by it  
or under its control U/S 4.1 (b) (vi)**

Ø; ¼1½	uLrh@i ath dk uke ½½	fo"k; ½½	vof/k ¼1½
	<b>LFkki uk 'kk[kk</b>		
01	deþkfj; ka dh I ok i qLrdka	deþkfj; ks ds I ok I Ecl/kh	deþkfj; ks ds I ok ea mi fLFkfr fnukad I s I ok fuoRr fnukad rd
02	deþkfj; ka dh 0; fDrxr~uLrh	deþkfj; ka dh 0; fDrxr~uLrh	deþkfj; ks ds dk; ky; ea mi fLFkfr fnukad rd
03	mi fLFkfr i ath	deþkfj; ka dh mi fLFkfr fooj.k	okf"kd
04	uLrh jftLVj i ath	uflr; ka dh i ath	yeh vof/k
05	oru of) i ath	deþkfj; ka ds oru of) I s I EcfU/kr	yeh vof/k
06	f'kdk; r i ath	f'kdk; r I Ecl/kh	yeh vof/k
07	vkdfLed vodk'k i ath	deþkfj; ka ds vodk'k I Ecl/kh	okf"kd
08	U; k; ky; hu i d j.k	U; k; ky; I s I EcfU/kr i d j.k ka dh i ath , oa uLrh	yeh vof/k
09	xksi uh; pfj=koyh uLrh	deþkfj; ka dh xksi uh; pfj=koyh I s I EcfU/kr uLrh	yeh vof/k
	<b>ys[kk 'kk[kk</b>		
10	ds k cpd	vk; &0; ; dk fooj.k	yeh vof/k
11	dfUvutv	vk; &0; ; dk fooj.k	yeh vof/k
12	fcy jftLVj	vk g j .k I Ecl/kh	yeh vof/k
13	pd jftLVj	pd vkod	yeh vof/k
14	, DoVBI jksy	Hkqrku jI hn i ath	yeh vof/k
15	pkyku jftLVj	'kkI dh; tek jkf'k dh i ath	yeh vof/k
16	cd MRV jftLVj	cd MRV vkod&tkod	yeh vof/k
17	Vj , MokU	; k=k vfxe	yeh vof/k
18	Vh, - fcy jftLVj	deþkfj; ka ds ; k=k ns d dh i ath	yeh vof/k
19	, e-vkj-fcy jftLVj	deþkfj; ka esMdy fcy i ath	yeh vof/k
20	thi h, Q jftLVj	deþkfj; ka ds thi h, Q- i ath	yeh vof/k
21	thvkbZ, I jftLVj	deþkfj; ka ds thvkbZ, I i ath	yeh vof/k
22	R; ksjk vfxe	deþkfj; ka ds R; ksjk vfxe dk fooj.k	yeh vof/k
23	vukt vfxe	deþkfj; ks ds vukt vfxe dk fooj.k	yeh vof/k
24	Mhi h, Q- jft-	prfklz Js kh deþkfj; ka ds Hkfo"; fuf/k dk ys[kk	yeh vof/k
25	, e-ihVhI h6	jI hn cpd dk fooj.k	yeh vof/k

## rduhdh 'kk[kk

26	if'k{k.k uLrh	if'k{k.k I EclU/kh i = 0; ogkj dh uLrh	okf''kzd
27	ekfl d ixfr Qkby	dk; kzy; ds }kjk vk; kf'tr ekfl d if'k{k.k dh uLrh	okf''kzd
28	cBd I EclU/kh	I akfnr cBdka dh uLrh	okf''kzd
29	I ello; uLrh	I ello; I febr dh cBd I EclU/kh uLrh	okf''kzd
30	if'k{k.k Qkby	vk; kf'tr if'k{k.k I EclU/kh uLrh	okf''kzd
31	if'k{k.k dh mi fLFkfr iath	if'k{k.k.kkfFkz; ka dh mi fLFkfr iath	okf''kzd
32	ekuns forj.k iath	if'k{k.k ea0; k[; ku nsus dk ekuns dh iath	okf''kzd
33	if'k{k.k 0; ; iath	if'k{k.k ea0; ; I EclU/kh iath	okf''kzd
34	ekfl d ixfr Qkby	vk; kf'tr if'k{k.k dsekfl d ixfr dk foj.j.k uLrh	okf''kzd
35	Hkks ky cBd I EclU/kh Qkby	Hkks ky ea cBd I EclU/kh uLrh	okf''kzd
36	I ello; I febr cBd I EclU/kh Qkby	I ello; I febr dh cBd I EclU/kh Qkby	okf''kzd
37	I ello; I febr cBd iath	I ello; I febr dh cBd I EclU/kh iath	okf''kzd
38	ekLVj Qkby vkns k I EclU/kh	vkns kka dh uLrh	okf''kzd
39	Ql y mRi knu Qkby , oaiath	Ql y mRi knu Qkby , oaiath	okf''kzd
40	vkSk/kh; i kSk I EclU/kh Qkby , oaiath	vkSk/kh; i kSks I s I EclU/kh Qkby , oaiath	okf''kzd
41	I v/dke I EclU/kh Qkby , oaiath	I v/dke%ohfM; ks dkuQfUl a:½ I EclU/kh i = 0; ogkj dh uLrh , oaiath	okf''kzd
42	I ekpkj&i = I EclU/kh Qkby	I ekpkj&i = I EclU/kh uLrh	okf''kzd
43	vkod&tkod iath	dk; kzy; hu i=ka ds vkus o tkus I EclU/kh iath	okf''kzd

## LVkj

44	okgu iath@uLrh	okgu I s I EclU/kh iath , oauLrh	yach vof/k
45	ykk cpl	okgu I s I EclU/kr iath	yach vof/k
46	LVS kujh	dk; kzy; hu LVS kujh dk ys[kk&tks[kk uLrh	yach vof/k
47	MM LVkhd iath	dk; kzy; hu I kefxz; ka dk bankt iath	yach vof/k
48	dUT; flex iath	dk; kzy; hu I kefxz; ka dk bankt iath	yach vof/k
49	vLFkbbZ LVkj iath	I kefxz; ka dk foj.j.k	yach vof/k
50	nijHkk" k iath	nijHkk" k I s I EclU/kr	yach vof/k
51	fo qr iath	fo qr I s I EclU/kr	yach vof/k
52	nsud I ekpkj iath	v[kckj I s I EclU/kr	yach vof/k
53	onhZ iath	prfjkZ Js kh depkfj; ka dh onhZ iath	yach vof/k

**7- I- Structure of consultative committees in which public representatives are members including**

Name of the Committee  
Copy of the Orders/Circulars for formation  
Functions  
Members  
Duties and responsibilities  
Accessibility of minutes for public U/s 4.1 (b) (vii)

II Proceedings, Minutes of the Meetings (copy to be made available and be given in the electronic form with hypertext link)

**NIL**

**08-**

**I Name of the Board, Council, Committees etc. including members and their qualifications. (Original text to be given in electronic form) U/S 4.1 (b) (viii)**

**NIL**

**9. Directory of the officers and employees (to be linked with treasury data bank) U/S 4.1 (b) (ix)**

S.N.	Name	Designation	Address & Contact No., if any
01	Jh dsih-i.k.Ms	i kpk; l i Hkkjh	i ) e/kj dKlykuh] i Mjk jhok nijHkk"K fu- 220685 dk; kZy; 226088
02	Jh dsMh-fl g	l gk-xM&2	f>fj; k] jhok] jkei j gkml ds l keu\$ nijHkk"K 250135
03	Jh vkj-chfrokjh	l gk-xM&3	fujkyk uxj] jhok
04	Jh v'kkd dèkj feJk	xk-d-fo-vf/k-	ug: uxj] jhok
05	Jh vfuy dèkj feJk	xk-d-fo-vf/k-	ug: uxj jhok
06	Jherh l jkst fl g	efgyk i n'kZ	d f"K blntuxj jhok

**10- Monthly remuneration and compensation (to be linked with treasury Data Bank) U/S 4.1 (b) (x)**

S.N	Name	Remuneration Gross Amount	Compensation
01	Jherh l jkst fl g	1065600	
02	Jh dsMhf l g	821500	
03	Jh jkeLo: i l kf/k; k	671300	
04	Jh Nk/syky 'kpyk	498300	
05	Jh v'kkcd dckj oekZ	537900	
06	Jh vkj-chfrokjh	592100	
07	Jh v'kkcd dckj feJk	930000	
08	Jh vfuy dckj feJk	883500	

**11 - Annual Budget allocation and Expenditure statement (to be linked with treasury Data Bank ( U/S 4.1(b) (xi)**

S. No.	Budget Head	Name of work	Year	Allocation	Expenditure
01	13-2415-0-1-004-2810	Salaries & Allowances & Contingency	2005-06	188000	113273
02	13-2401-00-001-0-119	Salaries & Allowances & Contingency	2005-06	162000	79842
03	13-2401-00-109-0-878	Salaries & Allowances & Contingency	2005-06	1163000	503274
04	13-2401-00-800-0-701 - 1580	ekbØkeust eW 05&06 , oa d f'k i f' k.k	2005-06	180000	12000
		<b>TOTAL</b>		<b>1693000</b>	<b>708389</b>

## 12- Programmes and beneficiaries U/S 4.1 (b) (xii)

A List of the Programmes (in electronic form)

B Norms for selection of the beneficiary (original text of the circular to be given in electronic form)

C Detailed Information

S No.	Name of the Programme	Administrative Department	Year	Amt. Allocated	No. of Beneficiaries
(1)	(2)	(3)	(4)	(5)	(6)
01	ekbØks ešusteeV ; kst uk vlr xr~ df"k folrkj , oa i pkj dk; Øe	I pkyd df"k Hkki ky	2005&06	1-65 yk[k	180
02	Nk=ofük , oa ofük; ka ; kst uk lrx xr~	I pkyd df"k Hkki ky	2005&06	0-15 yk[k	60

**13- List of the recipients and nature of concession U/S 4.1(b)  
(xiii)**

S.No.	Nature of concession	Name	Address	Year	Kind of support	Approximate value of Concession
			<b>NIL</b>			

**14- Information available in the office (Link with item 6) U/S 4.1  
(b) (xiv)**

SN	Categories	Hard Copy	Electronic Form
1-	0; ; ¼yku½	¶ykih	
2-	rduhdh tkudkjh	¶ykih	
3-	okgu l c¼kh	¶ykih	
4-	ctV	¶ykih	

**15- Facility available (liabrary, Public counter etc.) to citizen for information U/S 4.1(b) (xv)**

SN	Facility	Name of In charge	Duration of opening (time to be given)	Contract No. Telephone No.
		<b>NIL</b>		

16- Information about the PIO/Designation/Working experience U/S  
4.1(b) (xvi)

**Information**

Name : Jh dsi h- ik.Ms  
Designation : mi l pkyd df"k jhok ¼ ikjh ikpk; Z ½  
Tel. No. : 250070  
E-mail Address :  
Place of Work and Address : dk; kZ mi l pkyd df"k jhok  
Contract hours for public : 10%80 l s05%80 rd

**17 - Any other information in citizen related facilities U/S 4.1 (b)  
(xvii)**

**NIL**